

2024, Yr 0 - 2 T-ball Competition

Wednesday Afternoons 3:15 - 4:15 pm @ Bledisloe School fields

23rd October → 27th November 6 games, starting week 2 of term 4

Bledisloe School office, 844-2131

Y0-2 Wednesday	23rd October	30th October	6th November	13th November	20th November	27th November
Diamond 1 D1	Puketapu Vs Te Awa	Puketapu Vs Nelson Park	Puketapu Vs St. Pats Angels	Puketapu Vs GMS Green	Puketapu Vs AMS	Puketapu Vs. Bledisloe Tahī
Diamond 2 D2	Bledisloe Tahī Vs AMS	Bledisloe Tahī Vs Te Awa	Bledisloe Tahī Vs Nelson Park	Bledisloe Tahī Vs St. Pats Angels	Bledisloe Tahī Vs GMS Green	GMS Green Vs. Bledisloe Rua
Diamond 3 D3	Tamatea Vs GMS Green	Tamatea Vs AMS	Tamatea Vs Te Awa	Tamatea Vs Nelson Park	Tamatea Vs St. Pats Angels	Tamatea Vs. GMS Blue
Diamond 4 D4	GMS Blue Vs St. Pats Angels	GMS Blue Vs GMS Green	GMS Blue Vs AMS	GMS Blue Vs Te Awa	GMS Blue Vs Nelson Park	Nelson Park Vs Arthur Miller
Diamond 5 D5	Bledisloe Rua Vs Nelson Park	Bledisloe Rua Vs St. Pats Angels	Bledisloe Rua Vs GMS Green	Bledisloe Rua Vs AMS	Bledisloe Rua Vs Te Awa	Te Awa Vs St. Pats Angels

*If the games are to be canceled due to the weather, your school office will be notified by lunchtime (12:30 pm) on the Thursday.

Ngā mihi, Rosalie Stevens

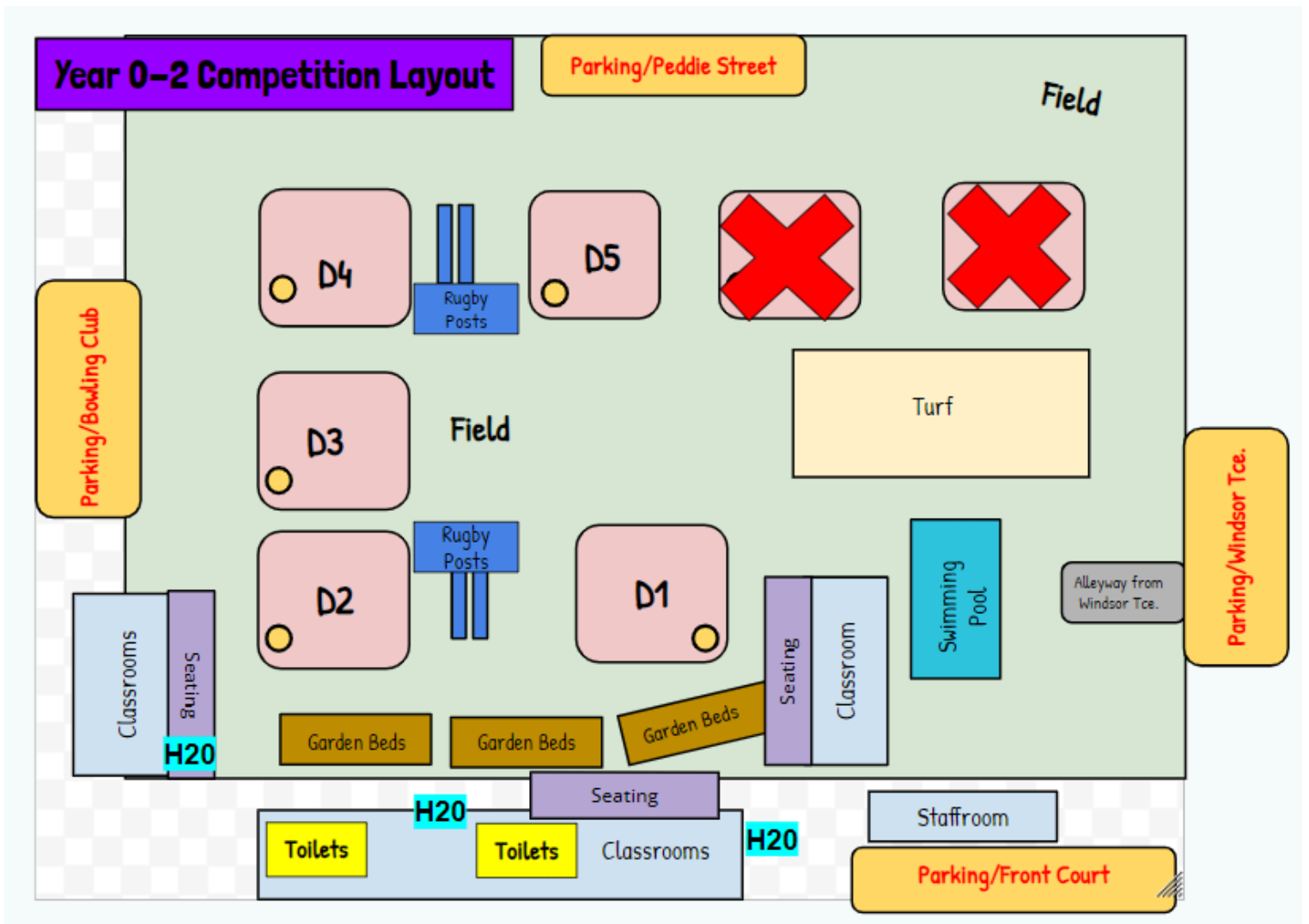

Map

Here is a map of the fields that will be marked and played at Bledisloe School.

T-ball Rules, Information & Scoring Sheet

Please bring a bat, a ball, and your first aid kit. There is no start time, you will begin play when your opposition arrives. Team numbers can be negotiated (fair/even) at times of play. Enjoy!

Rules

I have attached the Kiwi t-ball rules, however, please note for this year's 0-2 competition, the ball is to be thrown directly to the home base, not to each base). The batter continuously runs until the home base fielder yells, 'Stop!'

KIWI T-BALL

EQUIPMENT 'T' stand – 4 bases – Flexiball (SB162) – Bat
TEAMS 10 players
DIAMOND

- 10m between bases
- Base players behind bases
- Back-up players behind base players

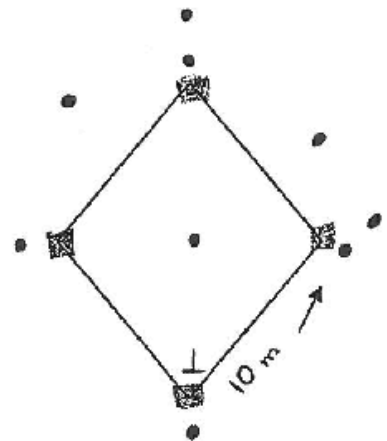

BATTING

Batter hits the ball off a 'T'. Keeps trying until it has gone at least 3 metres into fair territory (within the diamond). Batter runs to 1st base – second – third – first etc, putting foot on the base each time. Bat must be thrown clear to right on way to first base NOT thrown down or behind – batter is OUT if this is done.

Batter's turn finished when –

- The hit is caught
- Fielding team has thrown ball around diamond to home where the catcher calls loudly STOP!

The number of bases reached at this point is counted as runs scored. These accumulate until the whole team has batted.

NB: Batters sit in line at designated point well clear of home base.

FIELDING

Base players stand behind bases, not on them. The hit ball is fielded to base 1 player who puts foot on base and throws to second – third – home base – catcher calls 'stop' with ball in hand and foot on base. Ball is returned to 'T' for next batter.

Fielders need to 'back up' base players so they do not have to leave the base area.

Base players change each innings to give others a turn.

INNINGS

Each player bats before changeover. Aim at two innings each in the 45 minutes – if not completed, count score as at end of equal innings.

SCORING

One point for each base the batter reaches before the opposing catcher calls 'stop'. Accumulate points. Coach of team not refereeing to keep score and announce to both teams at the end.

FAIR PLAY

I suggest each coach awards a 'Fair Player Award' to a team member each week. It is important to get good attitudes established early!

SKILLS TO TEACH/PRACTISE

Batting Throwing Catching Base running Fielding back-up

REFEREEING

Use this as a teaching time for both teams if/when you see a need. Encourage '3 cheers' and thank you at end of game.

Scoring Sheet

TEE-BALL RECORDING SHEET

.....2010

FIRST INNINGS

<u>Primary School</u>							PRIMARY SCHOOL							
1	20	39	58	77	96	115	134	1	20	39	58	77	96	115	134
2	21	40	59	78	97	116	135	2	21	40	59	78	97	116	135
3	22	41	60	79	98	117	136	3	22	41	60	79	98	117	136
4	23	42	61	80	99	118	137	4	23	42	61	80	99	118	137
5	24	43	62	81	100	119	138	5	24	43	62	81	100	119	138
6	25	44	63	82	101	120	139	6	25	44	63	82	101	120	139
7	26	45	64	83	102	121	140	7	26	45	64	83	102	121	140
8	27	46	65	84	103	122	141	8	27	46	65	84	103	122	141
9	28	47	66	85	104	123	142	9	28	47	66	85	104	123	142
10	29	48	67	86	105	124	143	10	29	48	67	86	105	124	143
11	30	49	68	87	106	125	144	11	30	49	68	87	106	125	144
12	31	50	69	88	107	126	145	12	31	50	69	88	107	126	145
13	32	51	70	89	108	127	146	13	32	51	70	89	108	127	146
14	33	52	71	90	109	128	147	14	33	52	71	90	109	128	147
15	34	53	72	91	110	129	148	15	34	53	72	91	110	129	148
16	35	54	73	92	111	130	149	16	35	54	73	92	111	130	149
17	36	55	74	93	112	131	150	17	36	55	74	93	112	131	150
18	37	56	75	94	113	132	151	18	37	56	75	94	113	132	151
19	38	57	76	95	114	133	152	19	38	57	76	95	114	133	152
TOTAL RUNS:								TOTAL RUNS:							
CAUGHT OUT:								CAUGHT OUT:							

SECOND INNINGS

<u>Primary School</u>							PRIMARY SCHOOL							
1	20	39	58	77	96	115	134	1	20	39	58	77	96	115	134
2	21	40	59	78	97	116	135	2	21	40	59	78	97	116	135
3	22	41	60	79	98	117	136	3	22	41	60	79	98	117	136
4	23	42	61	80	99	118	137	4	23	42	61	80	99	118	137
5	24	43	62	81	100	119	138	5	24	43	62	81	100	119	138
6	25	44	63	82	101	120	139	6	25	44	63	82	101	120	139
7	26	45	64	83	102	121	140	7	26	45	64	83	102	121	140
8	27	46	65	84	103	122	141	8	27	46	65	84	103	122	141
9	28	47	66	85	104	123	142	9	28	47	66	85	104	123	142
10	29	48	67	86	105	124	143	10	29	48	67	86	105	124	143
11	30	49	68	87	106	125	144	11	30	49	68	87	106	125	144
12	31	50	69	88	107	126	145	12	31	50	69	88	107	126	145
13	32	51	70	89	108	127	146	13	32	51	70	89	108	127	146
14	33	52	71	90	109	128	147	14	33	52	71	90	109	128	147
15	34	53	72	91	110	129	148	15	34	53	72	91	110	129	148
16	35	54	73	92	111	130	149	16	35	54	73	92	111	130	149
17	36	55	74	93	112	131	150	17	36	55	74	93	112	131	150
18	37	56	75	94	113	132	151	18	37	56	75	94	113	132	151
19	38	57	76	95	114	133	152	19	38	57	76	95	114	133	152
TOTAL RUNS:								TOTAL RUNS:							
CAUGHT OUT:								CAUGHT OUT:							

FINAL SCORE _____

FINAL SCORE _____